

1. INTRODUCTION

Thank you for purchasing our high-temperature mass flow meter SEF-8240S series.

In order to use the apparatus correctly, please read this instruction manual thoroughly prior to using it.

This product has been shipped in combination with a vapor controller(VC series), unless otherwise specified by the client. See also the instruction manual for the VC series.

2. OVERVIEW

The SEF-8240S series is a small mass flow meter developed to be used in combination with the STEC's vapor controller(VC series). Since a control circuit and the main body are separated from each other, it is capable of baking up to 150 °C and operating up to 120 °C. With a heater and a thermocouple (K-type) incorporated, it is capable of easily heating by using a commercially available temperature controller together. The liquid material introduced into the VC series is vaporized when it passes through the VC series, and introduced into the SEF-8240S series. The SEF-8240S series measures a mass flow rate of the vapor and regulates an applied voltage to the piezo-actuator of the VC series by using a comparison control circuit to control a vaporization flow rate. This feedback control allows a stable flow rate to be produced at a use point.

3. PRINCIPLE OF FUNCTIONING

This mass flow meter consists of a flow rate sensor unit(main body) and a separate control circuit unit.

The flow rate sensor has two pairs of self heating type resistors coiled around a capillary tube and is connected to a bridge circuit. If a gas flows, there occurs a temperature difference between the up-stream and down-stream sides, changing a resistance value of the resistors. This change is measured by the bridge circuit and converted into a voltage signal proportional to a mass flow rate.

Then, this voltage signal is output (0 to 5 V) through an amplification circuit and a correction circuit.

The control circuit compares an external set voltage signal with a flow rate output signal and automatically controls the valve opening of the VC series so that the signals will coincide with each other. As this apparatus measures a mass flow rate, it allows stable flow rate control, free from effects of temperature and pressure changes.

4. SPECIFICATIONS

- (1) Flow rate range: 10/20/50/100/200/500 CCM (SCCM), 1/2/5 LM (SLM)
(N₂ conversion)
- (2) Measuring range: 0 to 100 % F.S.
- (3) Accuracy: ± 1 % F.S.
- (4) Linearity: ± 0.5 % F.S.
- (5) Repeatability: ± 0.2 % F.S.
- (6) Pressure resistance: 1.0 MPa (Gauge)
- (7) Accuracy assured temperature range: L-type 80 to 100
M-type 100 to 120
- (8) External leakage: 5×10^{-12} Pa \cdot m³/sec.(He) or less
- (9) Flow rate setting signal: 0 to 5 V DC (When combined with the VC series)
- (10) Flow rate output signal: 0 to 5 V DC
- (11) Material of the gas contact section: SUS316L
- (12) Baking temperature: Max.150 (At power-off)
- (13) Gas connection: 1/4" VCR Male type
- (14) Temperature sensor: Thermocouple (K-type)
- (15) Heater capacity: 120 V AC, 100 W (Cartridge heater 50 W \times 2 pieces)
- (16) Option: Special surface treatment (UC, SUC)

5. OUTER DIMENSIONS DRAWING

5-1.SEF-8240S MAIN BLOCK

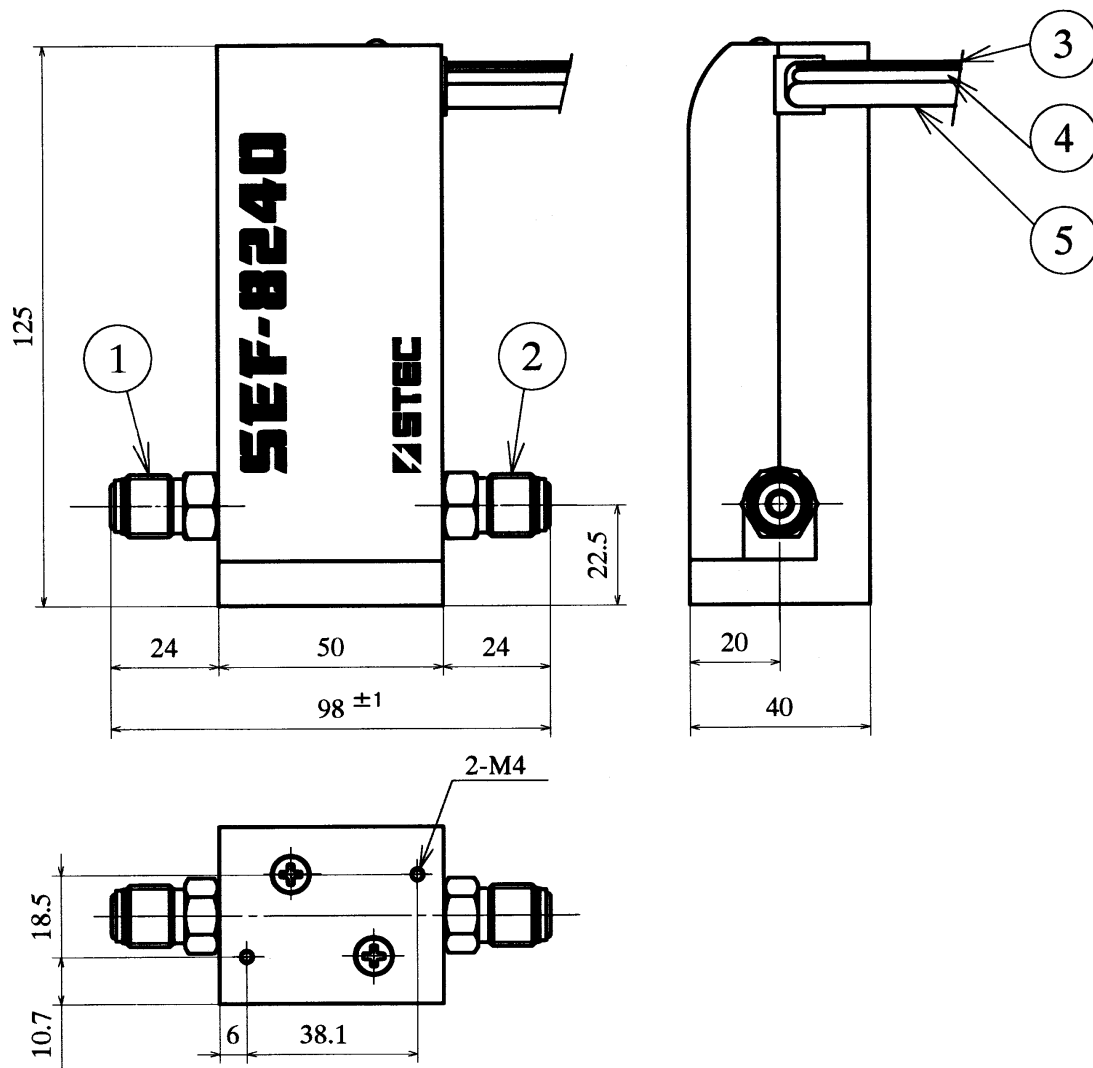

5	Cable	
4	Thermocouple	K type(CA)
3	Heater	100W(120V AC)
2	Outlet	1/4" VCR Male type
1	Inlet	1/4" VCR Male type
No.	Part Name	Note

5-2.SMT-8000A

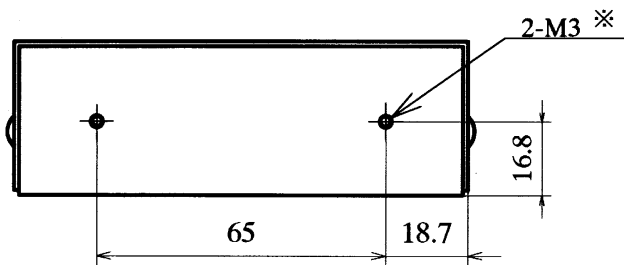
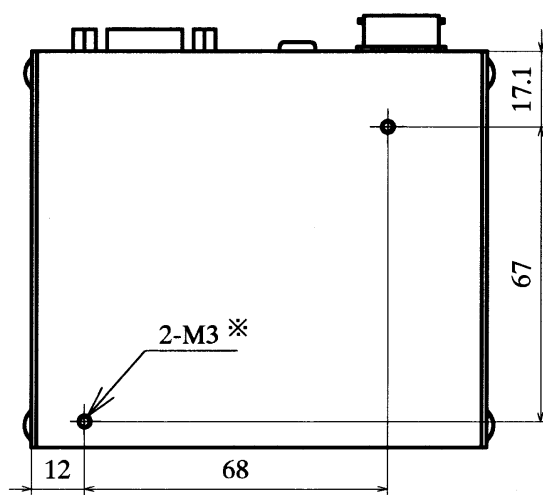
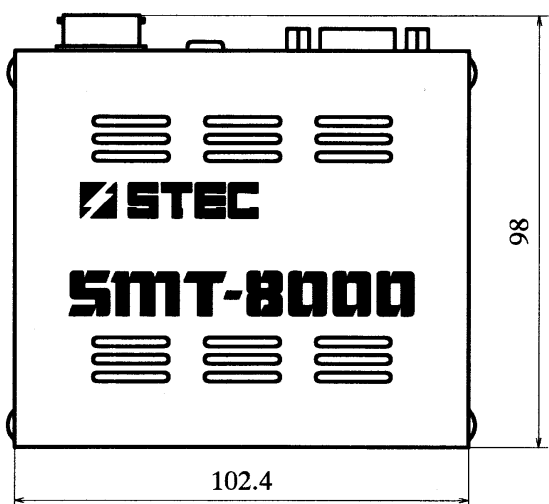
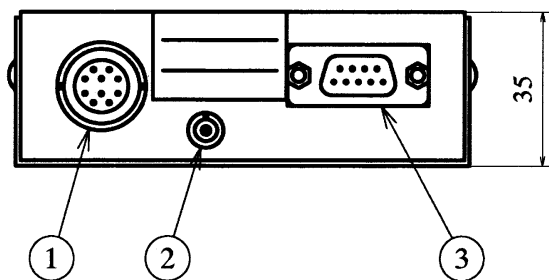

※ CAUTION
When installing, do not thrust screws into the body more than 10mm.

3	Connector(to Power supply)	17LE2304-22(DDK)
2	Connector(to VC series)	EGG00302CNL(LEMO)
1	Connector(to SEF-8240S)	RM15QRD-10S(HIROSE)
No.	Part Name	Note

6. ELECTRICAL CONNECTIONS

6-1 Connections the SMT-8000A to the Power Source and the Mass Flow Meter Body

The SMT-8000A incorporates a control circuit separated from the main body. It has three cable connectors. Connect cables to the respective connectors as shown below.

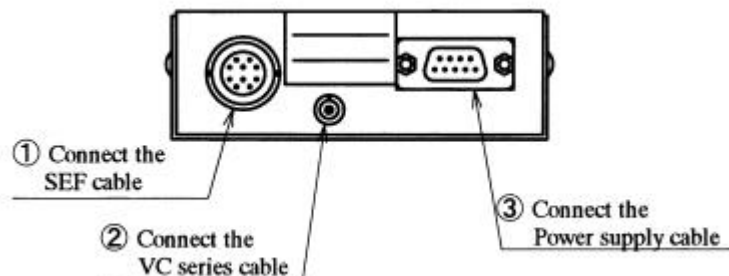

Drive power and SET/OUT signal connector

Connect the STEC's exclusive power source or the user-prepared power source and the SET/OUT signal according to the table below.

Connector used : D-Sub miniature 9 contact pin connector

Applicable plug: 17JE-13090-02(D8B) (DDK) and D-Sub connector equivalent

Connector Pin Signals Table

Pin No.	Signal
1	Valve Open/Close Input
2	Flow Rate Output 0 to 5 V DC
3	Power +15 V
4	Power COM
5	Power -15 V
6	Set Input 0 to 5 V DC
7	Output COM
8	Set COM
9	NC (Standard)

The DC power source used should have a capacity of
+15 V \pm 0.5 V, 60 mA or more and
-15 V \pm 0.5 V, 60 mA or more.

SEF-8240S main body connector

Connect a cable coming from the SEF-8240S series main body to this connector.
Connector used: RM15QRD-10S (HIROSE)

VC series connector

Connect a piezo-element drive cable for the VC series to this connector.
Connector used: EGG00302CNL (LEMO)

NOTE When the mass flow meter is used alone, this connector is not used.

6-2 Connecting the Mass Flow meter Main Body to the Temperature Controller

The mass flow meter incorporates a heater and a temperature sensor for heating and heat insulation, and their respective cables are coming out from the main body.

For temperature control of the main body, select and connect a temperature controller and an SSR(solid state relay) conforming to the specifications of the following heater and temperature sensor.

Heater cable

This is a cable for the cartridge heater built in the mass flow meter main body.
A heater capacity is 120 V AC, 100 W.

Thermocouple cable

This is a cable for a thermocouple(K-type) for measuring a temperature of the mass flow meter main body.

Connect it to a temperature sensor terminal of the temperature controller.

When making electrical connections, see 6-3 Example of System Configuration.

We have special purpose power units, setting units, and display units ready for your use.

Use of those special purpose units saves wiring labor and ensures safe operation.

For their types and other details, please contact our office.

STEC provides the HC-100 series as a temperature controller for the VC series, SEF series, and pipe heating. Use the HC-100V for the SEF-8240S series.

6-3 Example of System Configuration

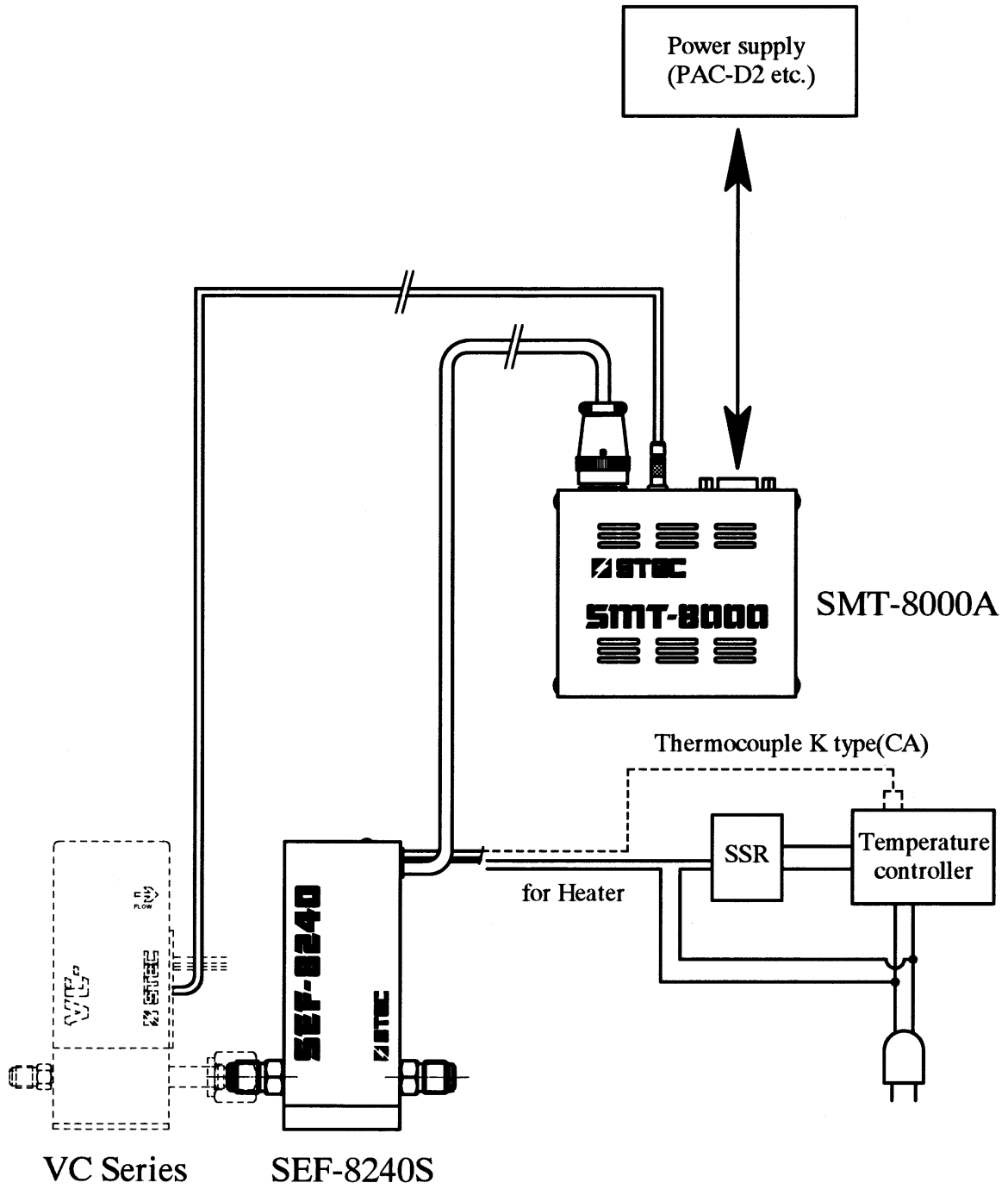

7. HOW TO USE

- 1) Connect the SEF-8240S to the down-stream side of the VC series, following the arrow-indicated direction.

NOTE In order to avoid recondensation, apply heat insulation to between the VC series and SEF-8240S series.

(If delivered in combination with the VC series and a heat insulating material has been applied to between the VC series and SEF-8240S series, the above-mentioned work is not required.)

NOTE The main body and the SMT-8000A can be installed and used in any posture.

- 2) Use a He leak detector, and so on to conduct a leak test on a gas line connection.

- 3) Make electrical connections according to “6. ELECTRICAL CONNECTIONS”.

CAUTION When this is done, be sure to turn off the power.

- 4) Turn on the power(± 15 V) and increase a temperature of the mass flow meter by means of the temperature controller. A warming up time is about 60 minutes.

NOTE When you want perform high-temperature baking, turn off the power(± 15 V).

- 5) Do not use the apparatus beyond its accuracy assured temperature range.

- 6) After warming the VC series and SEF-8240S series, fully close the control valve of the VC series by a valve opening/closing input.

NOTE The valve opening/closing input can open/close the VC series, regardless of a set voltage.

The VC series is fully closed by connecting -15 V to the No. 1 pin.

The VC series is fully opened by connecting +15 V to the No. 1 pin.

NOTE The same operation as compulsory closing is performed by inputting less than -0.6 V to a flow rate setting signal.

- 7) A set voltage to obtained a required flow rate value can be calculated by the following linear conversion formula.

$$\text{Set voltage} = \frac{\text{Required flow rate}}{\text{Full scale flow rate}} \times 5.000 \text{ V}$$

- 8) See the instruction manual for the VC series for the procedures for liquid introduction, start-up, and generation.

8. CARE FOR HANDLING **CAUTION**

- 1) Check that there are no leaks from the piping system.
- 2) Be sure to turn off the power when you make electrical connections.
- 3) A withstand voltage for flow rate setting input is a supply voltage ± 15 V.
Never apply a voltage beyond these limits.
- 4) A flow rate output of the mass flow meter is transiently made within a range of the supply voltage ± 15 V. When making use of the flow rate output, heed a withstand voltage of an input unit.
- 5) We converts a flow rate value into 25 , 1 atm.(CCM/LM) or 0 , 1 atm.(SCCM, SLM) to calibrate the apparatus.

ml/min (25 ,1atm)	:	CCM
l/min (25 ,1atm)	:	LM
ml/min (0 ,atm)	:	SCCM
l/min (0 ,1atm)	:	SLM
- 6) When you want to use a gas other than a calibration gas, consult us.
- 7) When you want to perform baking, turn off the power beforehand.
- 8) Take care that a baking temperature will not exceed 150 .

9. PRODUCT WARRANTY

9-1. PERIOD

One year after purchasing the machine. As for the trouble or failure caused and informed to us during this period, we will repair for nothing.

9-2. SCOPE

The scope of the guarantee is limited to the present machine. Compensation for loss due to the failure of the present machine is out of scope.

9-3. RENEWAL PARTS

Either of 90 days after the previous renewal or the term provided in 15-1, which is longer.

9-4. HOLD HARMLESS CLAUSE

The following cases, even during the term of guarantee, will be out of the scope.

- 1) Failure due to force majeure such as a natural disaster.
- 2) Failure due to customer's mistreating or negligence to the care for operation.
- 3) In case where used or stored under improper conditions.
- 4) In case where operated out of the rated specifications.
- 5) In case where the machine is revamped or used for other purpose than specified.
- 6) Other cases to be considered out of our responsibility.